



탱크 트럭용 용적식 유량계

■ 특성

- 탱크 트럭용 용적식 유량계는 높은 정확도와 반복성을 유지합니다.
- 압력손실이 적습니다.
- 등유, 석유, 휘발유, LPG, 기타 화학유체에 사용가능합니다.



APPLICATION

- Petroleum products
- Gasoline and jet fuels
- Treat water
- Acid PH Liquids
- Crude Oil, viscous liquids
- Liquefied Petroleum Gas(LPG)
- Most of industries (water, oil, solvent...)
- Chemical & Pharmaceutical
- Automotive, Agriculture
- Animal feeds, Food & Beverage

■ 제품사양

모델	TCS40	TCS50	TCS50H	TCS80	TCS80H	TCS100	TCS100H
사이즈(mm)	40	50		80		100	
유량범위(LPM)	25-250	38-380	55-550	75-750	115-1150	130-1300	170-1700
최대압력	10bar/150PSI						
정확도(%)	0.5						
반복도(%)	0.2						
유체단위	Liter/Gallon						

DY FLOWTECH Inc.

#135-2, Gagok-li, Hwado-yp, Namyangju-si, Geonggi-do, 472-841, Korea
TEL : +82-31-594-4748 FAX : +82-31-594-4749 E-mail : dyit4514@naver.com



■ 모델선택

MODEL ACCESSORIES

	NO STRAINER NO AIR ELIMINATOR NO VALVE	STRAINER NO AIR ELIMINATOR NO VALVE	STRAINER AIR ELIMINATOR NO VALVE	NO STRAINER NO AIR ELIMINATOR VALVE	STRAINER NO AIR ELIMINATOR VALVE	STRAINER AIR ELIMINATOR VALVE
COUNTER NO PRINTER NO PRE-SET						
COUNTER PRINTER NO PRE-SET						
COUNTER PRE-SET NO PRINTER						
COUNTER PRINTER PRE-SET						
NO COUNTER NO PRINTER NO PRE-SET						

■ 도면

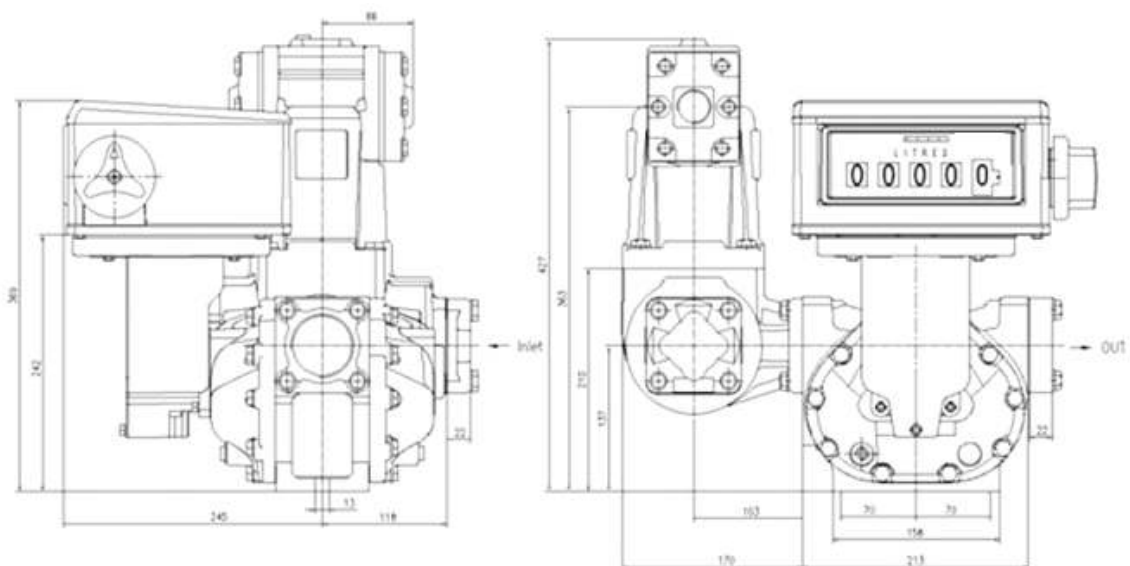

DY FLOWTECH Inc.

#135-2, Gagok-li, Hwado-yp, Namyangju-si, Geonggi-do, 472-841, Korea
 TEL : +82-31-594-4748 FAX : +82-31-594-4749 E-mail : dyit4514@naver.com